

ER2 Dual Speed inverter

With Hook Suspension

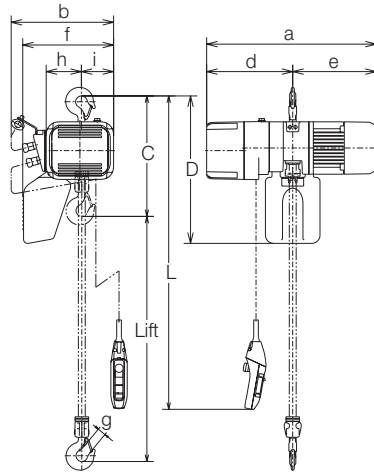

- Five meters of power supply cable as standard accompanies.
- Optional length of lift, push button cord and power supply cable besides standard is available on your request.
- Extending the load chain is prohibited with additional links.
- Steel chain containers are available as option as shown in Section of "Chain Containers" if your lift is more than capacity of the standard container volume.

Specifications

Capacity (t)	Product Code	Hoist Body	Standard Lift (m)	Push Button Cord L (m)	Lifting Motor		Lifting Speed (m/min)*			Load Chain		Classification ISO/FEM/ASME	Test Load (t)	Net Weight (kg)	Additional Weight per 1m Lift (kg)
					Output (kW)	Rating (%ED)	50/60Hz		Diameter (mm)	Chain Falls					
							High	Low							
125kg	ER2-001IH	B			0.56		Preset	16.6	2.8	4.3	x 1		156kg	27	0.42
	Adjustable							1.4							
250kg	ER2-003IS				0.9		Preset	10.8	1.8				313kg	36	
	Adjustable							0.9							
500kg	ER2-003IH	C			0.56		Preset	15.7	2.6	6	x 1	M5/2m/H4	625kg	32	0.81
	Adjustable							1.3							
1	ER2-005IL	D	3	2.5	0.9	40/20	Preset	4.5	0.8	7.7	x 1		1.25	45	1.33
	Adjustable							0.4							
1.5	ER2-010IS	E			1.8		Preset	8.5	1.4				1.88	72	
	Adjustable							0.7							
2	ER2-015IS	F			3.5		Preset	4.2	0.7	10.2	x 1		2.5	73	2.3
	Adjustable							0.3							
2.5	ER2-020IS				1.8		Preset	8.2	1.4				3.13	100	2.8
	Adjustable							0.7							
3	ER2-025IS	E			3.5		Preset	5.3	0.9	11.2	x 1	M4/1Am/H4	3.75	105	4.7
	Adjustable							0.4							
5	ER2-030IS	F			2.8		Preset	4.3	0.7	10.2	x 2		6.25	128	5.6
	Adjustable							0.4							
5	ER2-050IS				2.8		Preset	6.6	1.1	11.2	x 2		6.25	128	5.6
	Adjustable							0.6							
5	ER2-050IS				2.8		Preset	5.2	0.9	11.2	x 2		6.25	128	5.6
	Adjustable							0.3							

Note: The high speed is preset to the maximum speed in KITO factory. The speeds are adjustable between High and Low.

Dimensions (mm)

Capacity (t)	Product Code	Headroom C	D	a	b	d	e	f	g	h	i
125kg	ER2-001IH	350	430	535	345	276	259	284	27	99	117
250kg	ER2-003IS										
250kg	ER2-003IH	370	490	568	348	300	271	283	27	113	106
500kg	ER2-005IS										
1	ER2-010IL	430	550	614	376	316	298	335	31	129	118
	ER2-010IS										
1.5	ER2-015IS	510	630	710	427	372	338	384.5	34	160.5	137.5
2	ER2-020IS	575									
2.5	ER2-025IS	590		767		411	356	39			
2.5	ER2-025IS	625	840	800	445	401	399	437.5		173.5	142.5
3	ER2-030IS	785	920	767	427	411	356	397	44	216	82
5	ER2-050IS	850									
5	ER2-050IS	850		800	445	401	399	439	47	231.5	84.5

ER2 Dual Speed 500V pole change

With Hook Suspension

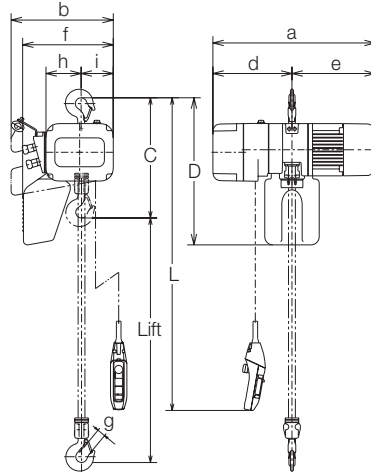

- Five meters of power supply cable as standard accompanies.
- Optional length of lift, push button cord and power supply cable besides standard is available on your request.
- Extending the load chain is prohibited with additional links.
- Steel chain containers are available as option as shown in Section of "Chain Containers" if your lift is more than capacity of the standard container volume.

Specifications

Capacity (t)	Product Code	Hoist Body	Standard Lift (m)	Push Button Cord L (m)	Lifting Motor		Lifting Speed (m/min)	Load Chain		Classification ISO/FEM/ASME	Test Load (t)	Net Weight (kg)	Additional Weight per 1m Lift (kg)
					Output (kW)	Rating (%ED)		50Hz	Diameter (mm) x Chain Falls				
125kg	ER2-001HD	B					14.2/3.5	4.3 x 1			156kg	31	0.42
250kg	ER2-003SD						7.2/1.8				313kg		
500kg	ER2-005LD	C					3.6/0.9	6 x 1	M5/2m/H4		625kg	39	0.81
	ER2-005SD						7.1/1.8				43		
1	ER2-010LD	D	3	2.5		40/20	3.5/0.9	7.7 x 1			1.25	56	1.33
	ER2-010SD						7.2/1.7					58	
1.5	ER2-015SD						4.8/1.2				1.88	74	
2	ER2-020LD	E					3.7/0.9	10.2 x 1			2.5	76	2.3
	ER2-020SD						6.9/1.6					97	
2.5	ER2-025SD	F					5.5/1.3	11.2 x 1	M4/1Am/H4		3.13	108	2.8
3	ER2-030SD	E					4.4/1.0	10.2 x 2			3.75	113	4.7
5	ER2-050SD	F		2.8			2.8/0.6	11.2 x 2			6.25	134	5.6

Dimensions (mm)

Capacity (t)	Product Code	Headroom C	D	a	b	d	e	f	g	h	i
125kg	ER2-001HD	350	430	478	321	219	259	260	27	99	93
250kg	ER2-003SD			513							
500kg	ER2-005LD	370	490	513	348	242	271	283	27	113	106
	ER2-005SD			533			291				
1	ER2-010LD	430	550	589	376	291	298	335	31	129	118
	ER2-010SD			615			324				
1.5	ER2-015SD	510		646	427	308	338	384.5	34	160.5	137.5
2	ER2-020LD	575	630	737							
	ER2-020SD	590									
2.5	ER2-025SD	625	840	736	445	337	399	437.5		173.5	142.5
3	ER2-030SD	785	920	737	427	347	390	397	44	216	82
5	ER2-050SD	850		736	445	337	399	439	47	231.5	84.5