

# ER2 Single Speed

With Hook Suspension

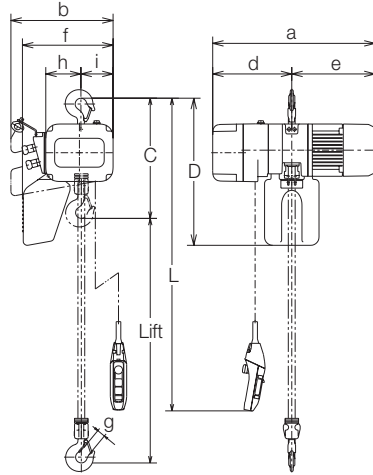

- Five meters of power supply cable as standard accompanies.
- Optional length of lift, push button cord and power supply cable besides standard is available on your request.
- Extending the load chain is prohibited with additional links.
- Steel chain containers are available as option as shown in Section of "Chain Containers" if your lift is more than capacity of the standard container volume.

## Specifications

Capacity (t)	Product Code	Hoist Body	Standard Lift (m)	Push Button Cord L (m)	Lifting Motor		Lifting Speed (m/min)		Load Chain		Classification ISO/FEM/ASME	Test Load (t)	Net Weight (kg)	Additional Weight per 1m Lift (kg)
					Output (kW)	Rating (%ED)	50Hz	60Hz	Diameter (mm)	Chain Falls				
125kg	ER2-001H	B			0.56		14.1	16.9	4.3	x 1		156kg	27	0.42
250kg	ER2-003S						9.1	10.9				313kg		
	ER2-003H	0.9	13.4	16.1	6	x 1	M5/2m/H4	625kg	33	0.81				
500kg	ER2-005L	C							0.56			3.8	4.6	7.7
1	ER2-010L				D	3	2.5	0.9		60		3.5	4.2	
	ER2-010S	7.1	8.5	54										
1.5	ER2-015S				1.8		4.5	5.4				1.88	72	
2	ER2-020L	E					3.7	4.4	10.2	x 1		2.5	73	2.3
	ER2-020S						7.0	8.4					91	
2.5	ER2-025S	F			3.5		5.7	6.8	11.2	x 1	M4/1Am/H4	3.13	104	2.8
3	ER2-030S	E					4.4	5.3				10.2	x 2	
5	ER2-050S	F		2.8			2.9	3.5	11.2	x 2		6.25	132	5.6

## Dimensions (mm)

Capacity (t)	Product Code	Headroom C	D	a	b	d	e	f	g	h	i
125kg	ER2-001H	350	430	478	321	219	259	260	27	99	93
250kg	ER2-003S			510		268					
	ER2-003H	510		268							
500kg	ER2-005L	370	490	513	348	242	271	283	27	113	106
	ER2-005S			510		268					
1	ER2-010L	430	550	589	376	291	298	335	31	129	118
	ER2-010S			598			307				
1.5	ER2-015S	510		646		308	338		34		
2	ER2-020L	575	630	703	427	347	356	384.5	39	160.5	137.5
	ER2-020S	590									
2.5	ER2-025S	625	840	736	445	337	399	437.5		173.5	142.5
3	ER2-030S	785	920	703	427	347	356	397	44	216	82
5	ER2-050S	850		736	445	337	399	439	47	231.5	84.5