

# CDER2 Cylindrical Control Dual/Single Speed

with Hook Suspension



Dual Speed

Single Speed

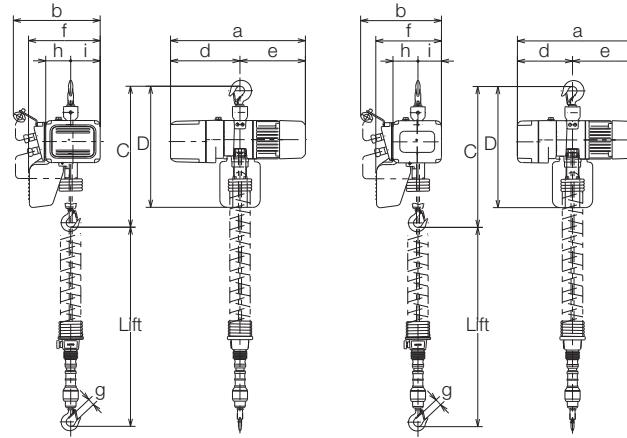

Dual Speed

Single Speed

- Five meters of power supply cable as standard accompanies.
- Length of lift, push button cord and power supply cable is standard only available.
- Extending the load chain is prohibited with additional links.
- Plastic chain container is provided only.

## Specifications

Capacity (t)	Product Code	Hoist Body	Standard Lift (m)	Lifting Motor		Lifting Speed (m/min)*		Load Chain		Classification ISO/FEM/ASME	Test Load (kg)	Net Weight (kg)	Additional Weight per 1m Lift (kg)
				Output (kW)	Rating (%ED)	50/60Hz		Diameter (mm)	Chain Falls				
						High	Low						
Dual	125kg ER2C001IH	B	1.8	0.56	40/20	Preset	16.6	2.8	4.3 x 1	M5/2m/H4	156	29	0.42
						Adjustable	10.8	1.4					
	250kg ER2C003IS					Preset	10.8	1.8					
						Adjustable	10.8	0.9					

Note: The high speed is preset to the maximum speed in KITO factory. The speeds are adjustable between High and Low.

## 500V

Capacity (t)	Product Code	Hoist Body	Standard Lift (m)	Lifting Motor		Lifting Speed (m/min)		Load Chain		Classification ISO/FEM/ASME	Test Load (kg)	Net Weight (kg)	Additional Weight per 1m Lift (kg)
				Output (kW)	Rating (%ED)	50Hz		Diameter (mm)	Chain Falls				
Dual	125kg ER2C001HD	B	1.8	0.5/0.13	40/20	14.2/3.5				4.3 x 1	M5/2m/H4	156	34
	250kg ER2C003SD					7.2/1.8		313					

Capacity (t)	Product Code	Hoist Body	Standard Lift (m)	Lifting Motor		Lifting Speed (m/min)		Load Chain		Classification ISO/FEM/ASME	Test Load (kg)	Net Weight (kg)	Additional Weight per 1m Lift (kg)
				Output (kW)	Rating (%ED)	50Hz	60Hz	Diameter (mm)	Chain Falls				
Single	125kg ER2C001H	B	1.8	0.56	60	14.1	16.9			4.3 x 1	M5/2m/H4	156	30
	250kg ER2C003S					9.1	10.9	313					

## Dimensions (mm)

Capacity (t)	Product Code	Headroom C	D	a	b	d	e	f	g	h	i
125kg	ER2C001IH	1065	490	535	345	276	259	284	27	99	117
250kg	ER2C003IS			478	321	219					
125kg	ER2C001HD	1065	490	478	321	219	259	260	27	99	93
250kg	ER2C003SD										
125kg	ER2C001H	1065	490	478	321	219	259	260	27	99	93
250kg	ER2C003S										