

ER2 Large Capacity

With Hook Suspension

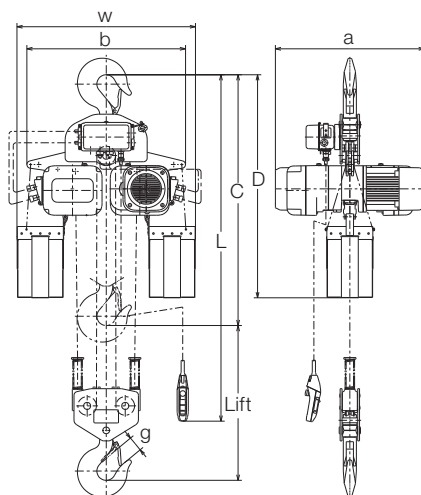

- Ten meters of power supply cable as standard accompanies.
- Optional length of lift, push button cord and power supply cable besides standard is available on your request.
- Extending the load chain is prohibited with additional links.
- Steel chain containers are available as option as shown in Section of "Chain Containers" if your lift is more than capacity of the standard container volume.

Specifications

Capacity (t)	Product Code	Hoist Body	Standard Lift (m)	Push Button Cord L (m)	Lifting Motor		Lifting Speed (m/min)		Load Chain Diameter (mm) x Chain Falls	Classification ISO/FEM/ASME	Test Load (t)	Net Weight (kg)	Additional Weight per 1m Lift (kg)
					Output (kW)	Rating (%ED)	50Hz	60Hz					
10	ER2-100S			3.4			2.9	3.5	11.2 x 4		12.5	303	11
15	ER2-150S	F	3	3.7	3.5x2	60	1.9	2.3	11.2 x 6	M4/1Am/H4	18.8	404	17
20	ER2-200S						1.4	1.7					

Dimensions (mm)

Capacity (t)	Product Code	Headroom C	D	a	b	w	g
10	ER2-100S	1370	1210		849	956	80
15	ER2-150S	1595	1520	798	1022	1129	86
20	ER2-200S	1710	1600		1198	1305	102